

Osptek Display

AMOLED SPECIFICATION

Model No:

E1394AA65.A

osptek[®]

Contents

Version History	2
Contents	3
1 Scope	4
2 Features	4
2.1 Product Applications	4
2.2 Product Features	4
3 Maximum Rating	4
4 Mechanical Specifications	4
5 Electrical Specifications	5
5.1 Electrical Characteristics	5
5.2 I/O Connection and Block Diagrams	5
5.3 Initial CODE	7
5.4 Graphic memory writing direction	8
5.5 Recommended Operating Sequence	8
5.6 AC Characteristics (MIPI)	9
6 Electro-Optical Specification	12
7 Reliability	15
7.1 Environmental Test	15
7.2 Electrical Test	16
7.3 Mechanical Test	16
8 Handling Precautions	16
9 Outline Dimension Drawing	17

osptek[®]

1 Scope

This Specification defines AMOLED manufactured by Shenzhen Osprey Optoelectronics Technology Co., Ltd. from here on refer as OSP. In the case of any unspecified item, it may require both OSP and the party designs this module into its product to work out a solution.

2 Features

2.1 Product Applications

Smart Watch

2.2 Product Features

- 1) Display color: 16.7M (RGB x 8bits)
- 2) Display format: 1.39"(454RGBx454)
- 3) Pixel arrangement: Real RGB arrangement
- 4) Interface: MIPI/SPI
- 5) Driver IC: RM69330

3 Mechanical Specifications

Parameter	Symbol	Spec			Unit	Note
		Min.	Typ.	Max.		
Analog/boost power voltage	VCI	-0.3	-	5.5	V	-
I/O voltage	VDDIO	-0.3	-	5.5	V	-
Operating temperature	Top	-20	-	60	°C	-
Storage temperature	Tstg	-30	-	70	°C	-

4 Maximum Rating

Item	Specification	unit
Dimension outline	38.83(V) x 38.21(W) x 0.68(T)	mm
LTPS Glass outline	38.83(V) x 38.21(W)	mm
Encapsulation Glass outline	φ38.21	mm
Number of dots	454(W) x RGB x 454(H)	dots
Active area	φ35.412	mm
Diagonal size	1.39	inch
Pixel pitch	78 x 78	μm

Glass thickness (LTPS/encapsulation glass)	0.2 / 0.2	mm
Weight	TBD	g

5 Electrical Specifications

5.1 Electrical Characteristics

5.1.1 Power Characteristic:

Item	Symbol	Min.	Typ.	Max.	Unit	Remark
Battery power Voltage	Vbat	2.9	3.7	4.8	V	-
Digital Power supply	VDDIO	1.65	1.8	1.95	V	Ref

1) Normal Mode

Power Supply: VDDIO=1.8V Vbat=3.7V

Frame Frequency: $F_{frame}=60\text{HZ}$ @ 25degC, Brightness 450 nits, Command Mode

Display Condition	Symbol	Min.	Typ.	Max.	Unit	Remark
100% Pixel On 450nits	Normal mode	-	252	291	mW	Ref

2) Idle Mode

Power Supply: VDDIO=1.8V Vbat=3.7V

Frame Frequency: $F_{frame}=15\text{HZ}$ @ 25degC, Brightness 30 nits, Command Mode

Display Condition	Symbol	Min.	Typ.	Max.	Unit	Remark
10% Pixel On,30nits	Idle mode	-	12	15	mW	Ref

3) Deep Standby Mode

Display Condition	Symbol	Min.	Typ.	Max.	Unit	Remark
All Pixel Off,0nits/ Vci off/Vddio on	Standby mode	-	-	10	μW	-

5.2 I/O Connection and Block Diagrams

#	Pin name	I/O	Description
1	XRES	I	Device reset signal (0 : enable ; 1 : Disable)
2	VCI_EN	I	VCI enable signal
3	VPP	-	OTP
4	GND	Power	Ground
5	TE	O	Synchronous signal output from panel to avoid tearing effect
6	DSI_D0N	I/O	MIPI data negative signal
7	AM_SPI_CSX	I	SPI interface
8	DSI_D0P	I/O	MIPI data positive signal
9	AM_SPI_SCL	I	SPI interface
10	GND	Power	Ground
11	AM_SPI_DCX	I	SPI interface
12	DSI_CLKN	I	MIPI strobe negative signal
13	AM_SPI_SDI	I/O	SPI interface
14	DSI_CLKP	I	MIPI strobe positive signal
15	AM_SPI_SDO	I/O	SPI interface
16	GND	Power	Ground
17	ID(H)	-	ID pin
18	VDDIO	Power	Power supply for interface system except MIPI interface
19	VBAT	Power	AMOLED power
20	VDDIO	Power	Power supply for interface system except MIPI interface
21	VBAT	Power	AMOLED power
22	VBAT	Power	AMOLED power
23	VBAT	Power	AMOLED power
24	VBAT	Power	AMOLED power

5.3 Initial CODE

1. Power On Sequence				
W/R	Type	Register	Parameter	Description
				Turn on VCI
				Delay (No Limit)
				Turn on VDDIO
				Delay (No Limit)
				Turn on VBAT
				Delay >10ms
				Reset pin high
				Delay >10ms
				MIPI初始化
				Delay >1ms
w	0x15	0xFE	0x07	
w	0x15	0x15	0x04	SRAM Read adjust control
w	0x15	0xFE	0x00	User Command
w	0x15	0x35	0x00	enable TE
w	0x15	0x3A	0x75	用于调整16bit rgb
w	0x15	0x51	0xFF	
w	0x15	0x2A	0x00	
w			0x0E	
w			0x01	
w			0xD3	
w	0x15	0x2B	0x00	
w			0x00	
w			0x01	
w			0xC5	
w	0x05	0x11		sleep out
				Delay >120ms
w	0x05	0x29		display on

5.4 Graphic memory writing direction

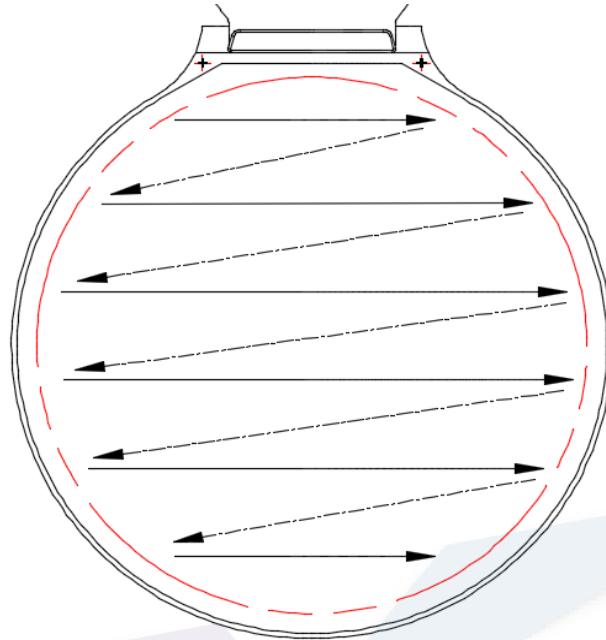

5.5 Recommended Operating Sequence

5.5.1 Power on sequence

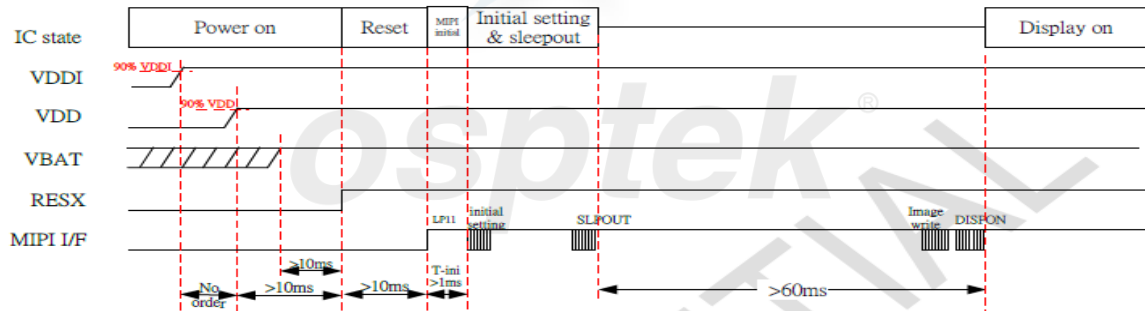

5.5.2 Power off sequence

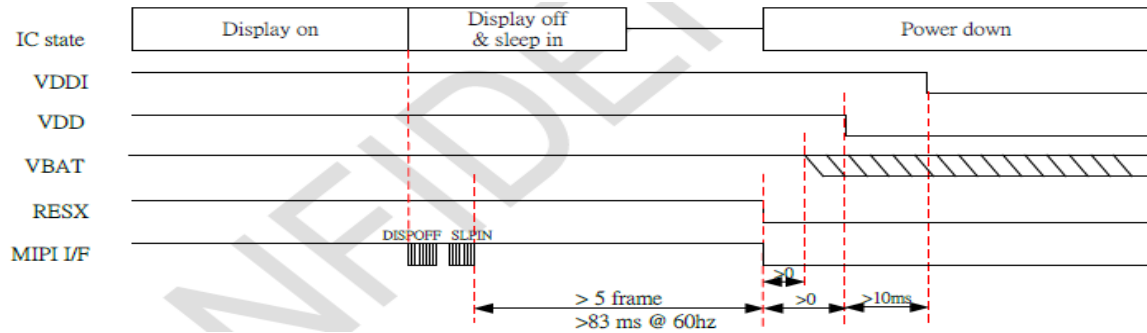

5.6 AC Characteristics (MIPI)

5.6.1 HS Data Transmission Burst

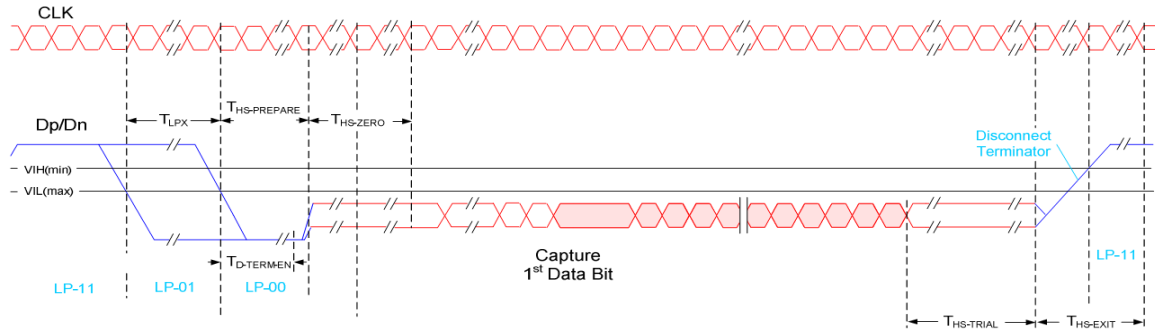

5.6.2 HS Clock Transmission

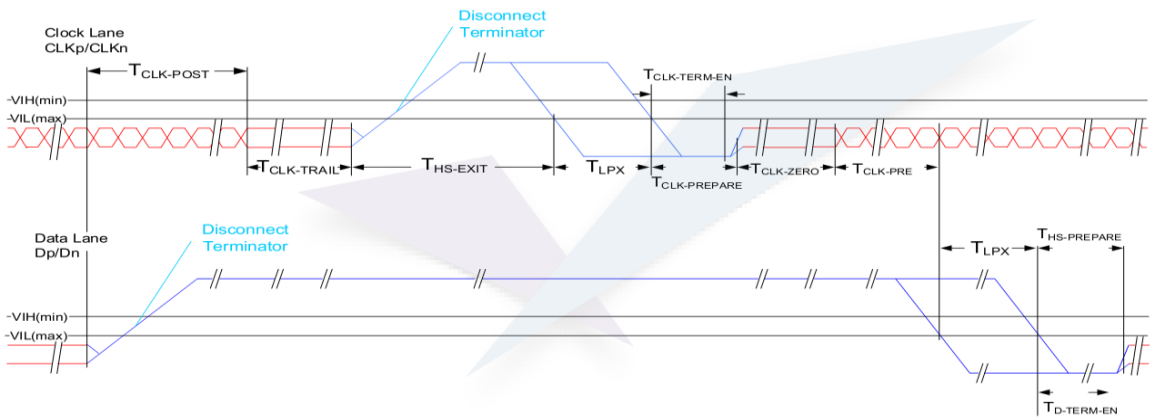

5.6.3 Turnaround Procedure

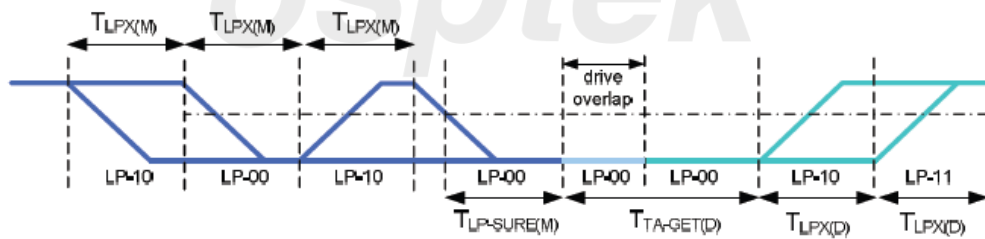

Bus turnaround (BAT) from MPU to display module timing

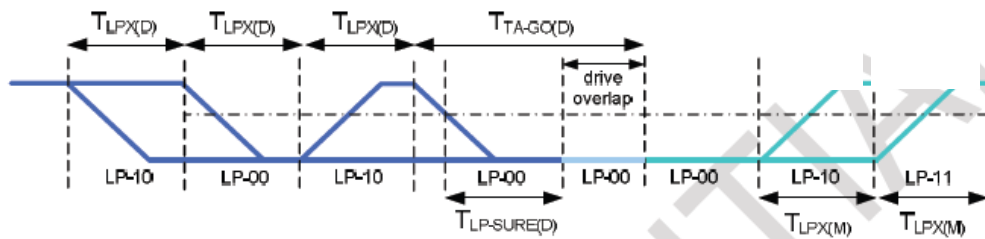

Bus turnaround (BAT) from display module to MPU timing

5.6.4 Timing Parameters

Symbol	Description	Min	Typ	Max	Unit
TREOT	30%-85% rise time and fall time	-	-	35	ns
TCLK-MISS	Timeout for receiver to detect absence of Clock transitions and disable the Clock Lane HS-RX.	-	-	60	ns
TCLK-POST*1	Time that the transmitter continues to send HS clock after the last associated Data Lane has transitioned to LP Mode. Interval is defined as the period from the end of THS-TRAIL to the beginning of TCLK-TRAIL.	$60\text{ns} + 52*UI$ (For DCS)	-	-	ns
TCLK-PRE	Time that the HS clock shall be driven by the transmitter prior to any associated Data Lane beginning the transition from LP to HS mode.	8	-	-	ns
TCLK-SETTLE	Time interval during which the HS receiver shall ignore any Clock Lane HS transitions, starting from the beginning of TCLK-PRE.	95	-	300	ns
TCLK-TERM-EN	Time for the Clock Lane receiver to enable the HS line termination, starting from the time point when Dn crosses VIL,MAX.			38	ns
THS-SETTLE	Time interval during which the HS receiver shall ignore any Data	$85\text{ ns} + 6*UI$		$145\text{ ns} + 10*UI$	ns

	Lane HS transitions, starting from the beginning of THSPREPARE.				
TEOT	Time from start of THS-TRAIL or TCLK-TRAIL period to start of LP-11 state	-	-	105ns+48*UI	ns
THS-EXIT(1)	time to drive LP-11 after HS burst	100	-	-	ns
THS-PREPARE	Time to drive LP-00 to prepare for HS transmission	40ns + 4*UI	-	85ns+6*UI	ns
THS-PREPARE + THS-ZERO	THS-PREPARE + Time to drive HS-0 before the Sync sequence	145ns + 10*UI	-	-	ns
THS-SKIP	Time-out at RX to ignore transition period of EoT	40	-	55ns+4*UI	ns
THS-TRAIL	Time to drive flipped differential state after last payload data bit of a HS transmission burst	60 + 4*UI	-	-	ns
TLPX	Length of any Low-Power state period	50	-	-	ns
Ratio TLPX	Ratio of TLPX(MASTER)/TLPX(SLAVE) between Master and Slave side	2/3	-	3/2	ns
TTA-GET	Time to drive LP-00 by new TX	5*TLPX	5*TLPX	5*TLPX	ns
TTA-GO	Time to drive LP-00 after Turnaround Request	4*TLPX	4*TLPX	4*TLPX	ns
TTA-SURE	Time-out before new TX side starts driving	TLPX	-	2*TLPX	ns

5.6.5 Timing requirements for RESETB

When RESETB of the reset pin equals to Low, it will be in the condition of reset.

When it is in the condition of reset, it will make the device recover the initial set.

However, in order to avoid the reset noise cause reset, there is a mechanism to judge about whether the reset is needed or not.

The closed interval of Low can be shown as the following.

(Test condition: VDDIO=1.65V~3.6V, VSS=0V, TA=-20°C~+70°C)

Parameter	Symbol	Conditions	Spec			Unit
			Min.	Typ.	Max.	
Reset low pulse width	Trst	-	20	-	-	μs

Table: Reset timing

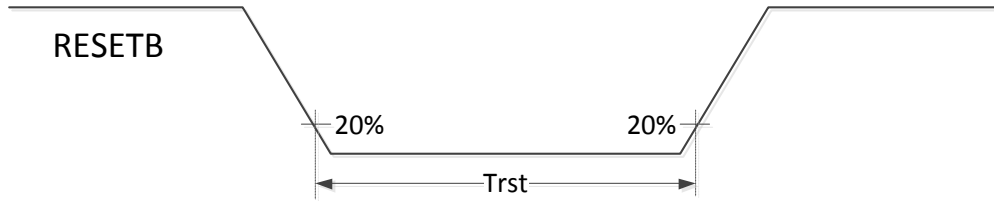

Figure: Reset timing

6 Electro-Optical Specification

Test condition: IOVCC=1.8V, VCI=2.8V, Ta=25°C

Item	Symbol	Condition	Value			Unit	Note	
			Min	Typ	Max			
Luminance		$\theta=0^\circ$	405	450	495	cd/m ²	Note 1	
Uniformity		$\Phi=0^\circ$	80	85	-	%	Note 2	
Viewing Angle	Left	θ_L	Cr≥200	80	85	-	Deg.	Note 3
	Right	θ_R		80	85	-		
	Top	ψ_T		80	85	-		
	Bottom	ψ_B		80	85	-		
Contrast Ratio	CR	$\theta=0^\circ$	10000	100000	-	-	Note 4	
Response Time	Tr+Tf	$\Phi=0^\circ$	-	2	3	ms	Note 5	
Color Coordinate of CIE1931	Red	X	$\theta=0^\circ$ $\Phi=0^\circ$	0.646	0.676	0.706	-	-
		Y		0.293	0.323	0.353		
	Green	X		0.18	0.22	0.27		
		Y		0.69	0.73	0.77		
	Blue	X		0.113	0.143	0.173		
		Y		0.014	0.044	0.074		
	White	X		0.28	0.30	0.32		
		Y		0.29	0.31	0.33		
NTSC Ratio	NTSC	CIE1931		103	-	%	-	
Flicker	-	-	-	-	-30	dB	-	
Gamma	-	-	1.9	2.2	2.5		Note 6	
Crosstalk	ΔCT	-	-	-	1.1		Note 7	

Note 1: Luminance measurement

The test condition is measured on the surface of AMOLED module at 25°C.

- Measurement equipment CS2000 or similar equipment (Field of view:1deg,Distance:50cm)
- Measuring surroundings: Dark room.
- Measuring temperature: Ta=25°C.
- Adjust operating voltage to get optimum contrast at the center of the display.

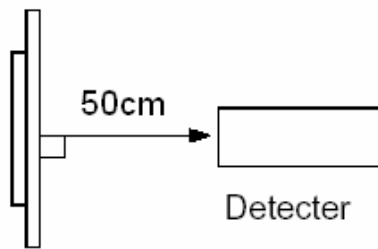

Note 2: Uniformity

The luminance uniformity is calculated by using following formula:

$$\Delta Bp = Bp (\text{Min.}) / Bp (\text{Max.}) \times 100 (\%)$$

Bp (Max.) = Maximum brightness in 5 measured spots

Bp (Min.) = Minimum brightness in 5 measured spots.

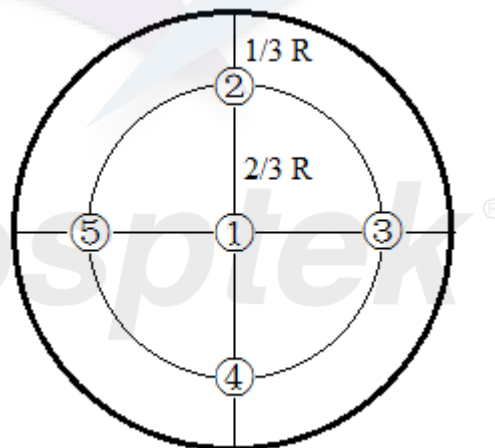

Note 3: The definition of Viewing Angle

Refer to the graph below marked by ϑ and ϕ

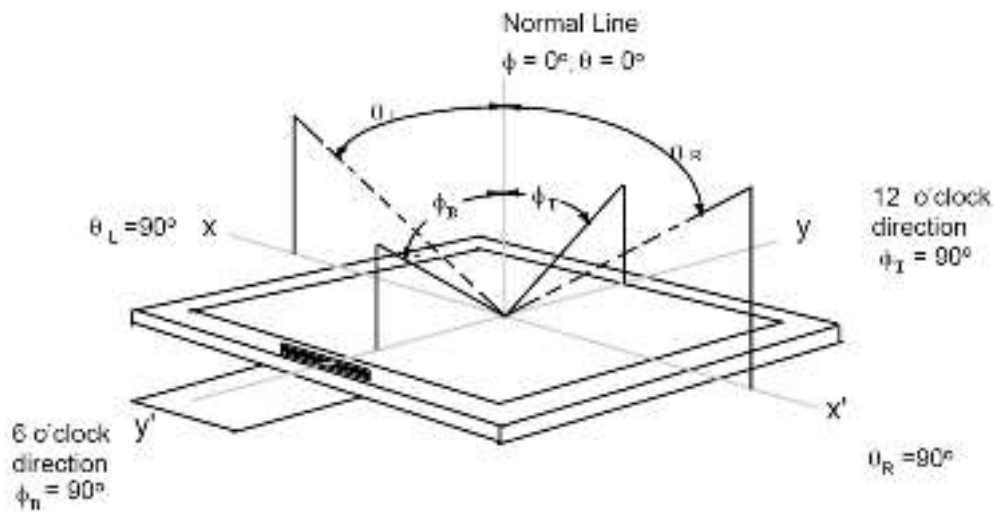

Note 4: The definition of Contrast Ratio:

$$\text{Contrast Ratio (CR)} = \frac{\text{Luminance When AMOLED is at "White" state}}{\text{Luminance When AMOLED is at "Black" state}}$$

Note 5: Definition of Response time.

The output signals of photo detector are measured when the input signals are changed from "black" to "white" (Voltage falling time) and from "white" to "black" (Voltage rising time), respectively. The response time is defined as the time interval between the 10% and 90% of amplitudes. Refer to figure as below.

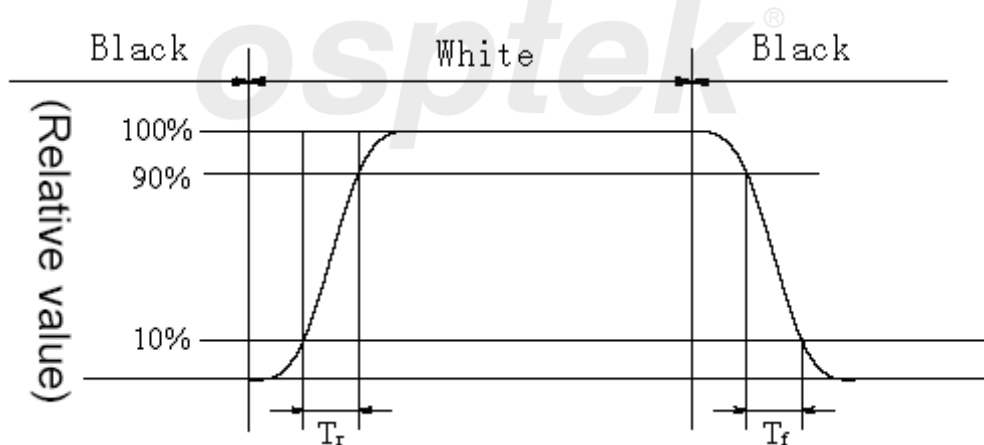

Note 6: Gamma curve

The whole curve's tolerance must control within +/-0.3, test the gray scale below:
 8, 16, 25, 33, 41, 49, 58, 66, 74, 82, 90, 99, 107, 115, 123, 132, 140, 148, 156, 165, 173, 181, 189, 197, 206, 214, 222, 230, 239, 255

Note 7: Crosstalk

There should be no visible cross-talk in normal direction of the display when the two

“Cross-talk Test Patterns” below are loaded.

ΔBp (Max.) = Maximum value in $\Delta Bp1 \sim \Delta Bp4$.

ΔBp (Min.) = Minimum value in $\Delta Bp1 \sim \Delta Bp4$.

$\Delta CT = \Delta Bp$ (Max.) / ΔBp (Min.).

ΔCT must be less than 1.10

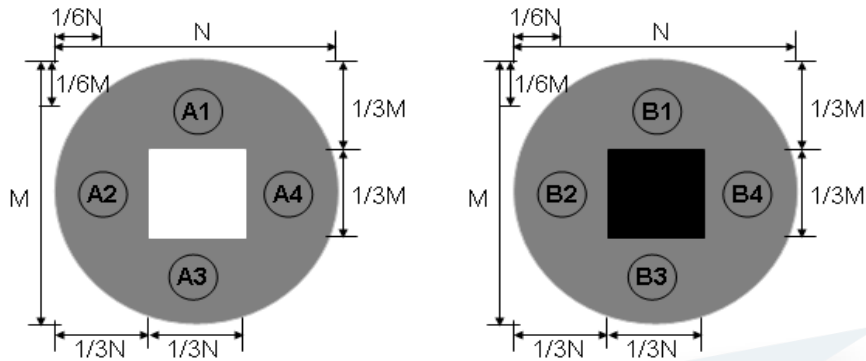

Cross-talk Test Pattern

7 Reliability

7.1 Environmental Test

Item	Main spec	No. of failures / No. of examinations
High Temperature Operation	70°C / 128hours	0 / 5
Low Temperature Operation	-20°C / 128hours	0 / 5
High Temperature Storage	80°C / 128hours	0 / 5
Low Temperature Storage	-30°C / 128hours	0 / 5
High Temperature Humidity Operation	60°C / 90%RH 128hours	0 / 5
Thermal Shock	-40°C ~ 80°C 0.5hr, 30 cycles	0 / 5

7.2 Electrical Test

Item(Display)	Main spec	Note
Air Discharge	±4kV , 150pF/330Ω (Module level)	5Points, Each 2times. No degradation of OLED performance after this test.
Contact Discharge	±4kV, 150pF/330Ω (Module level)	

7.3 Mechanical Test

Item	Main spec	Note
Drop Test	Drop the packing from 75cm height, 3 times for 6-faces, 3-edges and 1-corner	Package
Vibration-proof test	2g, f=10->55->10Hz apply in each of X, Y, and Z direction for 30 min	Package

8 Handling Precautions

1. When cleaning ITO pad, avoid using hard and abrasive material or corrosive solution
2. Keep module away from direct sunlight or fluorescent light, and keep it at room temperature and humidity
3. Strong impact & pressure on module and packing is prohibited
4. Following normal power on/off sequence is necessary for preventing abnormal display or permanent damage to display
5. Optimal contrast ratio under ideal voltage is AMOLED module's characteristic, hence it is recommended a voltage control function available
6. Image sticking may occur if an image displays for an extended period of time
7. When interfered by system's overall mechanical design, an abnormal display may occur
8. After considering emitting energy, you should plan your design to satisfy EMI standards.
9. Host side should place a surge-prevent circuit at power trace (ie: VCI, Vddi) to protect AMOLED module.

9 Outline Dimension Drawing

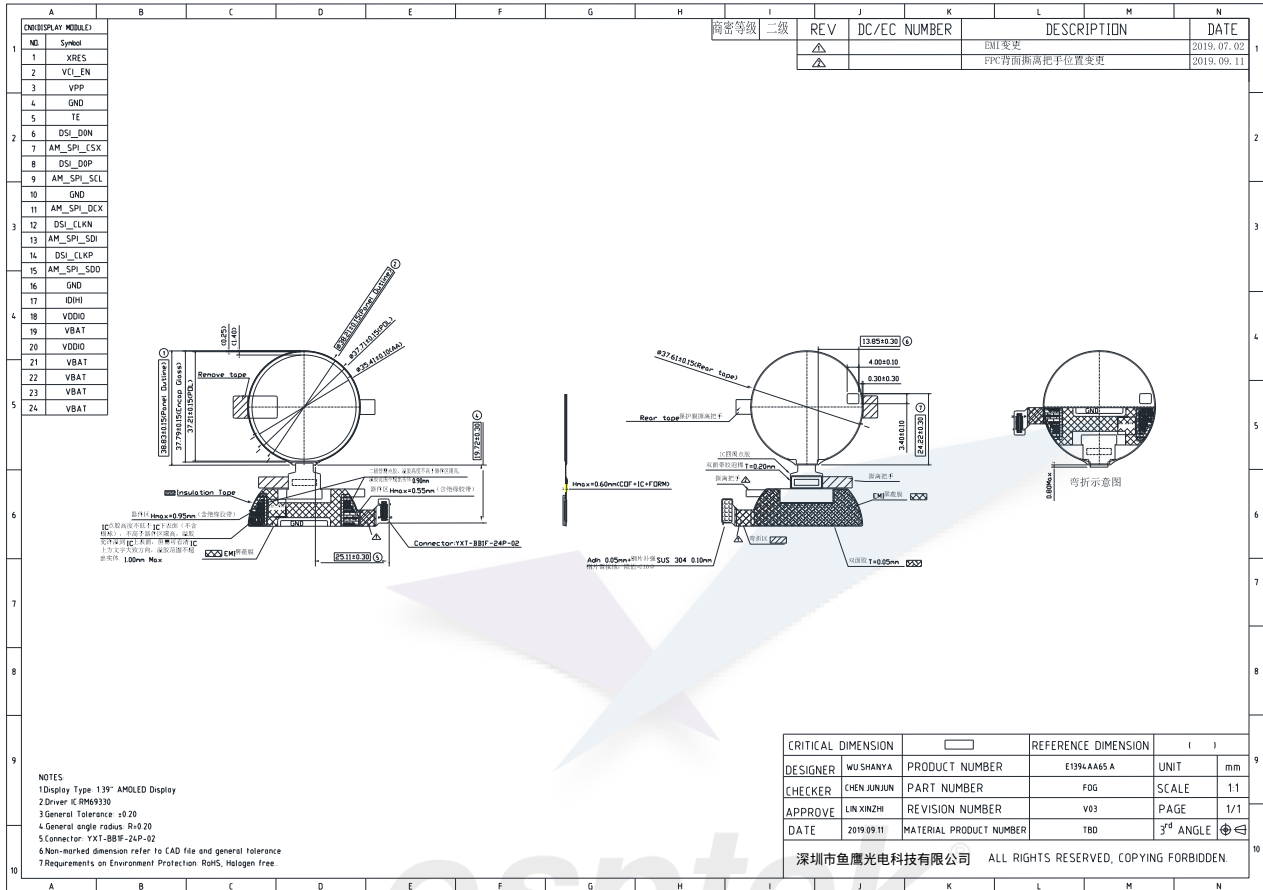

10 Packing Specification

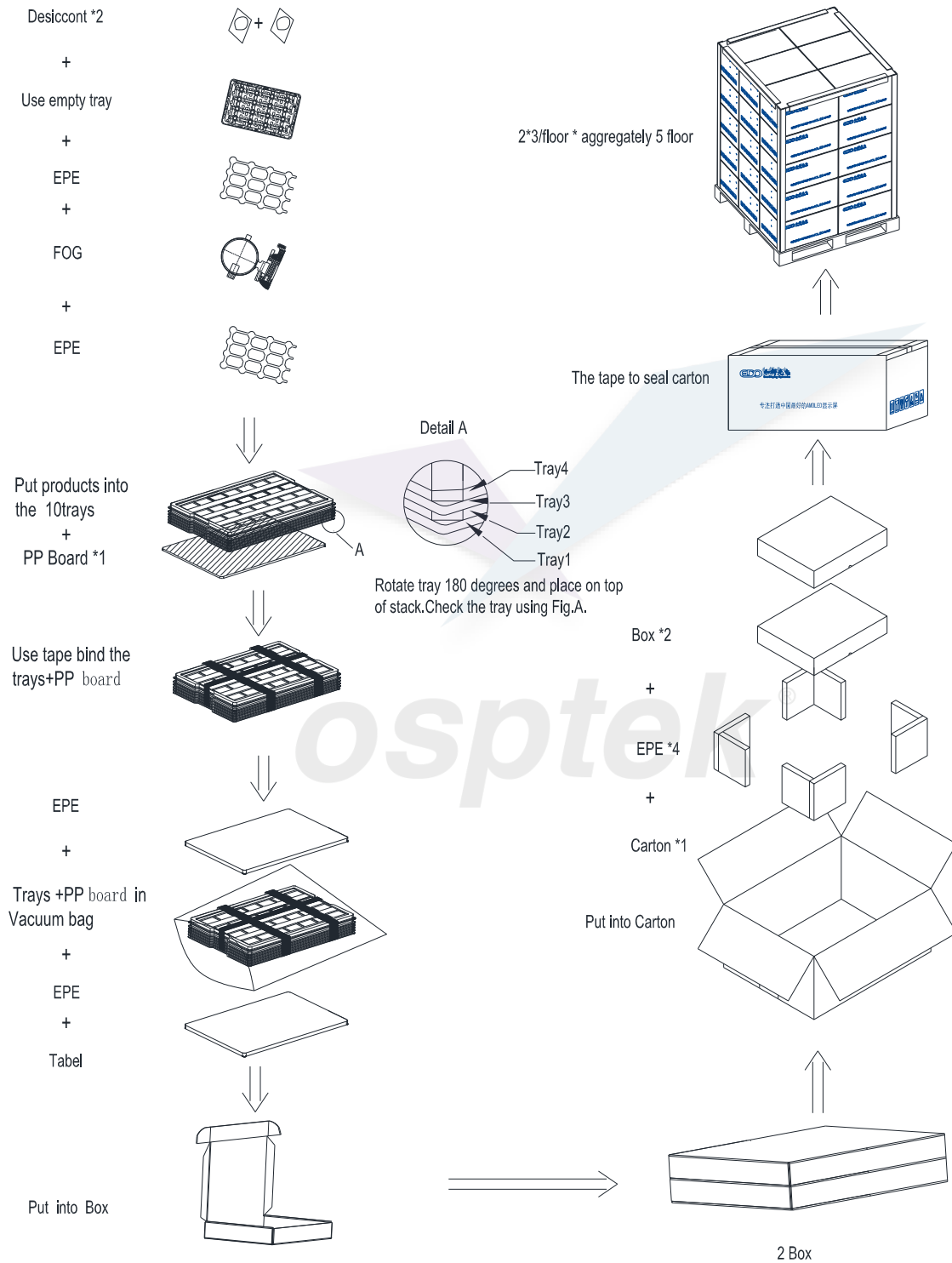

NO	品名	材质	尺寸(mm)	数量(个)	模组数量	备注
1	Label (外箱)	纸	52.00*100.00*0.10	1		
2	Label(内箱)	纸	100.00*52.00*0.075	2		
3	吸塑盘	PET	455.00*290.00*14.00	20		
4	EPE 填充物	EPE	356.35*222.61*1.00	36		
5	EPE 缓冲物	EPE	457.00*292.00*10.00	4		
6	纸箱	纸	516.00*338.00*248.00	1	288/箱	
7	纸盒	纸	459.00*294.00*115.00	2	144/盒	
8	干燥剂	干燥剂	55.00*75.00	4		
9	防尘袋	PE	660.00*440.00*0.28	2		
10	PP 板	PP	457.00*292.00*5.00	2		
11	EPE 缓冲物	EPE	120.00*244.00*100.00	4		
12	栈板	木材	TBD	1/30		



osptek®